



DOUBLETRIGA

The state-of-the-art universal milling cutter with 2 x 3 cutting edges per insert for maximum efficiency



STATE-OF-THE-ART UNIVERSAL MILLING SYSTEMS WITH 2 X 3 CUTTING EDGES PER INSERT

With **DOUBLETRIGA**, the latest entry in POKOLM's range of milling cutters, the engineers have delivered a genuine universal genius of state-of-the-art design. Six cutting edges per insert provide for maximum efficiency. On top of this, the advanced geometry guarantees high milling rates and excellent finish quality at the same time. High feed rates

of up to f_z 1.5 mm are possible.

The fully peripherally ground inserts with robust cutting edge profiles and a real corner radius of 3 mm are installed with positive locking and feature a positioning groove to avoid twisting.

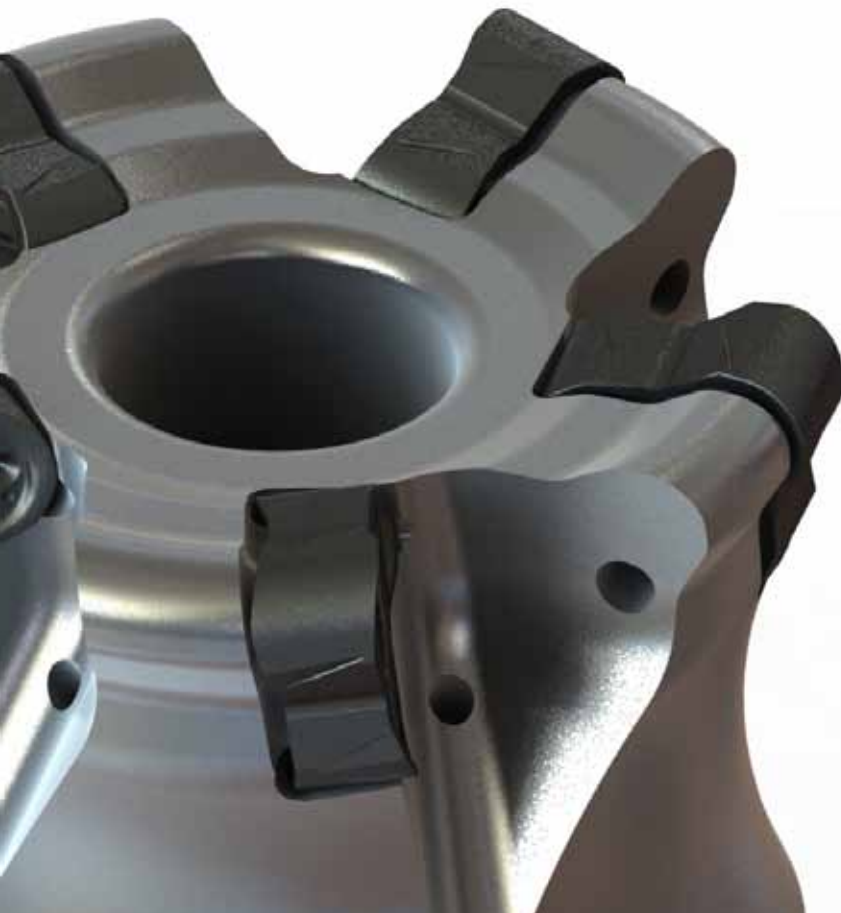
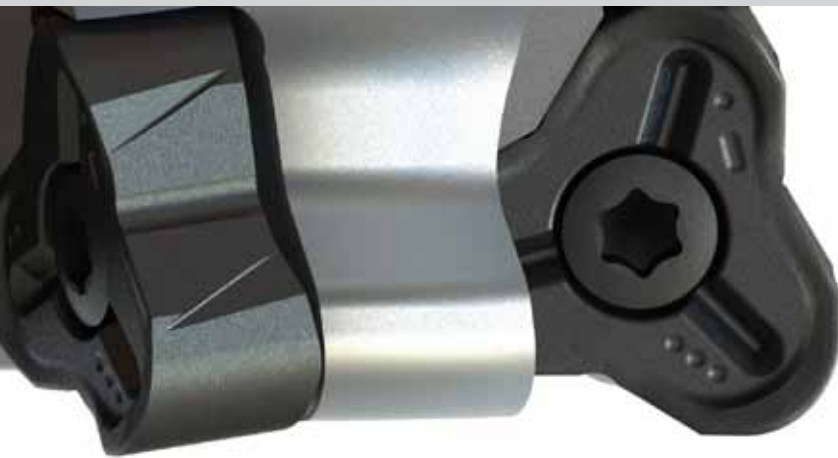

The **DOUBLETRIGA** milling system

- ⊕ 1.2 mm chamfer for circular finishing
- ⊕ 3 mm real corner radius
- ⊕ planar chamfer for planar finishing
- ⊕ Torx Plus system for long service life of the fastening screw
- ⊕ deep chip breaker for minimised chip compression and power consumption

Connections

DOUBLETRIGA tools are available as

- ⊕ Threaded shank and
- ⊕ shell-type milling cutters.

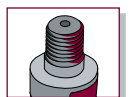

All tools feature an internal coolant supply for maximum process safety and reliable chip extraction.

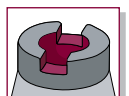

DOUBLETRIGA FEATURES AT A GLANCE

- ➔ six cutting edges per insert for maximum efficiency
- ➔ high cutting rate while maintaining an excellent finish quality
- ➔ high feed rates of up to f_z 1.5 mm are feasible
- ➔ 3 mm real corner radius
- ➔ state-of-the-art insert geometry with a robust cutting edge profile
- ➔ secure positioning and fixation with anti-twist protection of the inserts
- ➔ long service life and high process reliability

The insert seat:

- ➔ positive-locking three-point bearing for secure positioning and fixation of the insert
- ➔ large contact area for a long service life
- ➔ the insert seat features a cam to provide for additional anti-twist protection
- ➔ increased process reliability
- ➔ easy access

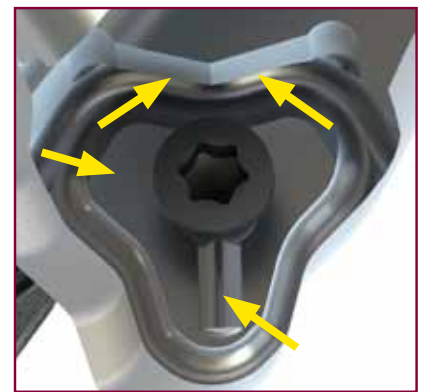

Insert seat

The disposable inserts:

- ➔ inserts fully peripherally ground on all sides
- ➔ all six cutting edges are uniquely labelled for easy identification
- ➔ positioning grooves for easy installation and anti-twist protection
- ➔ ground clearance angle for helical plunge milling
- ➔ robust cutting edge profile
- ➔ high positive chip angle
- ➔ ground planar chamfer



Insert

Part numbers follow a logical and easily understandable system:

Example: **2 32 290**

- ➔ No. of flutes
- ➔ Nominal diameter [d_1]
- ➔ Connection
 - 2 - Threaded shank end mill body
 - 3 - Shell-type milling cutter body
- ➔ System key
 - 90 - DOUBLETRIGA

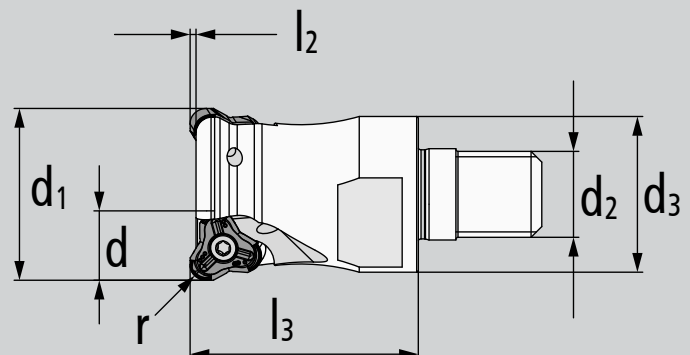



DOUBLETRIGA

Size M

- six cutting edges per insert for maximum efficiency
- high cutting rate while maintaining an excellent finish quality
- all tools feature an internal coolant supply
- high feed rates of up to f_z 1.5 mm are feasible
- secure positioning and fixation with anti-twist protection of the inserts

Milling cutter bodies	Catalogue no.											Accessories	Features
		d_1	d	r	l_3	l_2	l_1	d_2	d_3	z			

Threaded shank end mill bodies													
	2 32 290	32	12	3	42.5	1	-	M 16	29	2	A, C, D, E, F	<input checked="" type="checkbox"/>	
	3 35 290	35	12	3	42.5	1	-	M 16	29	3	A, C, D, E, F	<input checked="" type="checkbox"/>	

Shell-type milling cutter bodies													
	4 42 390	42	12	3	40	1	-	diam. 16	35	4	A, B, C, D, E, F	<input checked="" type="checkbox"/>	
	5 52 390	52	12	3	50	1	-	diam. 22	48	5	A, C, D, E, F	<input checked="" type="checkbox"/>	
	6 66 390	66	12	3	50	1	-	diam. 27	48	6	A, C, D, E, F	<input checked="" type="checkbox"/>	
	8 80 390	80	12	3	50	1	-	diam. 27	60	8	A, C, D, E, F	<input checked="" type="checkbox"/>	

Accessories					
<p>35 505 P Torx screw A > Page 6</p>	<p>GWSTPS8ISK hexagon socket set screw B > Page 6</p>	<p>POKOLM 10 500 P Torx-screwdriver C > Page 6</p>	<p>TV 1-5 Screwdriver Torque Vario®-S with window scale, D > Page 6</p>	<p>T10 500 P Torx interchangeable bit for Torque Vario® E > Page 6</p>	<p>T10 502 P, Torx MagicSpring com- patible bit f. Torque Vario®, F > Page 6</p>

Indexable inserts	Catalogue no.	DIN Specification	Carbide Grade	Coating				
					d	s	r	M
	05 90 850 R30	WNHX 125030 SR	P25	PVSR	12	5	3	M 3,5
	05 90 860 R30	WNHX 125030 SR	K10	PVTi	12	5	3	M 3,5

Recommended starting torque for Torx screw: 3 Nm

latest items!

available as long as stock lasts

on request

stock item, subject to confirmation

Feed per tooth (f_z) | d.o.c. (a_p)

Material		steel	stainless steel	cast iron	non-ferrous materials	high-temperature alloys	hardened steel
Quality Coating	Feed per tooth d.o.c.						
P25 PVSR	f_z (mm)	0.15-1.5	-	0.15-1.5	-	-	-
	a_p (mm)	0.1-1.5	-	0.1-1.5	-	-	-
K10 PVTi	f_z (mm)	0.15-1.5	-	0.15-1.5	-	-	-
	a_p (mm)	0.1-1.5	-	0.1-1.5	-	-	-

Cutting speed (v_c in m/min)

Material		steel	stainless steel	cast iron	non-ferrous materials	high-temperature alloys	hardened steel
Quality Coating	Application						
P25 PVSR	roughing	100 200 300	-	160 190 220	-	-	-
	finishing	150 200 250	-	160 190 220	-	-	-
K10 PVTi	roughing	130 175 220	-	150 185 220	-	-	-
	finishing	150 225 300	-	150 200 250	-	-	-





Extended operation data

Plunging	
Cutter diam. d_1	X_{max}
32-80	1

Ramping		
Cutter diam. d_1	α°	y
32	<3	17.2
35	<2.8	20.2
42	<2.1	27.2
52	<1.5	37.2
66	<1.1	51.2
80	<0.8	65.2

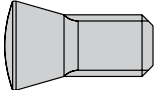
Helix		
Cutter diam. d_1	D_{min}	D_{max}
32	49.2	62
35	55.2	68
42	69.2	82
52	89.2	102
66	117.2	130
80	145.2	158

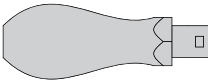
ACCESSORIES

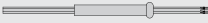
Accessories		Catalogue no.	Description			
Torx@screws Torx@screws						
	35 505 P	Torx screw M 3,5 L 9 T 10 Plus	M 3,5	L 9	T 10 Plus	
Additional screws and washers hexagon socket set screw						
	GWSTPS8ISK	hexagon socket set screw M 8x1.25 M8x0.75 hexa. size 4	M 8x1.25	M8x0.75	hexa. size 4	
Spanners / screwdrivers Torx-screwdriver						
	10 500 P	Torx-screwdriver T 10	T 10			
Torque screwdrivers and accessories Torque screwdrivers						
	TV 1-5	Screwdriver Torque Vario®-S with window scale from Nm 1.0 up to 5,0 Nm with scale, inc setter	from Nm 1.0	up to 5.0 Nm	with scale, incl. setter	
Torque screwdrivers and accessories Torx bits, standard						
	T10 500 P	Torx interchangeable bit for Torque Vario® T 10 L 175 max. 3.8 Nm	T 10	L 175	max. 3.8 Nm	
Torque screwdrivers and accessories Torx bits with retaining spring						
	T10 502 P	Torx MagicSpring compatible bit f. Torque Vario® T 10 L 175 max. 3.8 Nm	T 10	L 175	max. 3.8 Nm	

DOUBLETRIGA IN PRACTICAL TESTS - CONVINCING RESULTS

Material to be machined: ST52-3

Tool	5 52 390
Arbor	100 22 A100
Overhang [mm]	153 mm
Cooling	Air
Insert	05 90 850 R30
Coating	PVTi
v_c speed [m/min]	180
v_f feed rate [mm/min]	8500
$n(s)$ [min ⁻¹]	1100
d_z [mm]	52
f_z feed per tooth [mm]	1.54
a_p depth of cut [mm]	1.0
a_e width of cut [mm]	31.2
Tool life [min]	89
Life length [m]	756
Stock removal rate [cm ³ /min]	265.2

Wear patterns on insert 05 90 850 R30



Machining of a prototype mould for sheet metal forming. Despite the flame cut edges, a reliable cycle time of 90 min was achieved with all six cutting edges.

Material to be machined: 1.2344 / H13 - 35 HRC

Tool	3 35 290
Arbor	BT 40
Overhang [mm]	100
Cooling	Air
Insert	05 90 860 R30
Coating	K10 / PVTi
v_c speed [m/min]	200
v_f feed rate [mm/min]	3930
$n(s)$ [min ⁻¹]	1800
d_z [mm]	35
f_z feed per tooth [mm]	0.73
a_p depth of cut [mm]	1.5
a_e width of cut [mm]	60 %
Tool life [min]	> 70
Life length [m]	275
Stock removal rate [cm ³ /min]	123.8

1.2344 / H13: Component and chips



Mould insert being machined on a horizontal machining centre. The real corner radius of $4 r = 3.0$ mm allowed for conformal machining.



ООО «Венде Групп» Санкт-Петербург, Россия
офис: +7 812 456-72-01
почта: info@vende-group.ru
сайт: www.vende-group.ru

